

ILLUMINATED CROSSING PHONE

Metal Bodied Weather Resistant Telephone



UPDATED! INCLUDES NEW FEATURES

- **Cat. No. 87/037961**
- **Approved for Level Crossings**
- **PETS I and PETS II compatible**
- **Larger illuminated legend panel**
- **Raised stainless steel button**
- **Soft spring and magnetic catch on door**
- **Industry standard robust handset c/w armoured cord**
- **Selectable call timer**
- **Robust and weather resistant**
- **Up to IP65**
- **CB Operation only**
- **Clear, even illumination (white backlight)**
- **CE compliant**

Network Rail Certified Product

The Titan Illuminated Crossing telephone is specifically designed and approved for installation at automatic half barrier (AHB) level crossings with Public Emergency Telephone System (PETS I and PETS II).

The telephone is fitted with a white backlit legend panel, which can be used to provide visible instructions at night. A translucent legend sheet can be fitted into the slot provided, accessible only from inside the weather resistant seal.

The raised press-to-call button is stainless steel and vandal resistant. The telephone is CB operation only, where lifting the handset loops the line. The call button is configured to give a line break signal.

The handset is rugged, has an armoured cord and an integrity loop that will disconnect the illumination when broken (for example if vandalised).

The door uses a soft spring and magnetic catch, giving an ingress protection rating up to IP65 with the door closed.

Titan brings state of the art design and technology to metal bodied weather and vandal resistant telephones. It is simple to install and fixings are concealed from view. Cable entries are via standard 20mm glands.

GAI-Tronics Telephony

Illuminated Crossing Phone Metal Bodied Weather Resistant Telephone

TECHNICAL SPECIFICATIONS

Speech:

Transmission to BS6317:1982

Ringin

Input: 20-50Hz, 30-100V rms

Output: dual tone, 80dBa @ 1m. Typical REN 1

Illumination / On hook leakage:

On hook current 6mA \pm 10 %

Illumination is disconnected if the handset is vandalised

Illuminated panel:

83x90mm LED backlight (white). Includes a receptacle for a legend sheet (66x81mm), accessible from inside the case only

Signalling button:

Raised, stainless steel, vandal resistant button

Hookswitch:

Magnetic / electronic. No moving parts

Time Out:

Calls will terminate after approximately 7 minutes even if the handset is still off-hook. Can be disabled by internal jumper setting.

Power supply:

Powered from telephone line

On hook voltage: 20-70V

Off hook loop current: min 15mA

Temperature:

Operating: -20°C to +60°C

Storing: -40°C to +70°C

Relative Humidity:

Up to 95% (non-condensing)

Lightning / Transients

Protection to ITU-T k.21 enhanced levels

Casing material:

Die-cast aluminium, epoxy powder coated

Handset Material:

Cyclopol with stainless steel spiral cord

Weight:

5kg approx

Dimensions:

H 366 x W 189 x D 130 mm with door closed

DIMENSIONS:

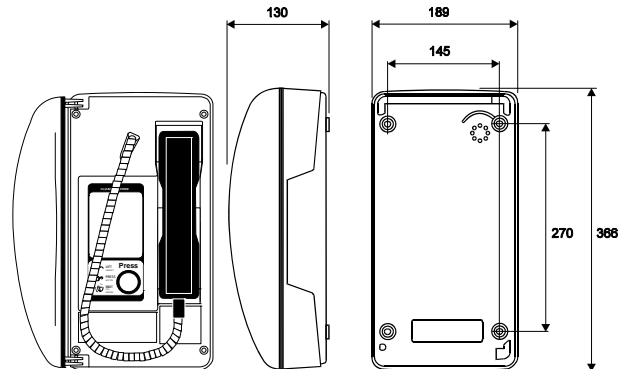

APPROVALS



CERTIFICATION

Certificate of Acceptance Number
PA05/01757



This mark indicates compliance with the following directives:

2004/108/EC- EMC Directive

2011/65/EC- RoHS 2 Directive

2006/95/EC- Low Voltage Directive

Telephone Network
Connection

BS6305

Telephone Handset
Safety
emc

BS6317

BS EN 60950-1

BS EN 50121-4, BS EN 55022,
BS EN 55024



The GAI-Tronics Quality Management System has been approved by LRQA to ISO9001:2008 & ISO 14001:2004 Certificate No. 861888 and OHSAS 18001:2007 Certificate No. 4004472



This mark indicates compliance for inductively coupling to Hearing Aids having a 'T' switch position Tested to ETS 300-381 and in accordance with ITU-T P37

For specific country approval, please call

ORDER CODE (for other variants, please call)

GAI-Tronics part number: 028-02-3191-652

PADS code: 87/037961 (replaces 87/037905 / 87/037943)

OPTIONAL ACCESSORIES ORDER CODE

Please ask for Brochure B150 or visit www.gai-tronics.co.uk



GAI-Tronics® - United Kingdom - Tel: +44 (0)1283 500500 - Fax: +44 (0)1283 500400 - www.gai-tronics.co.uk
GAI-Tronics® (Corporate) - USA - Tel: +1(610) 777 1374 - Toll Free: 800 492 1212 - Fax: +1(610) 796 5954 - www.gai-tronics.com
GAI-Tronics® S.r.l - Italy - Tel: +39 02 48601 460 - Fax: +39 02 4585 625 - www.gai-tronics.co.uk
GAI-Tronics® - Malaysia - Tel: +60 3 8945 4035 - Fax: +60 3 8945 4675 - www.gai-tronics.co.uk
GAI-Tronics® Austdac - Australia - Tel: 011 61 28 851 5000 - Fax: 011 61 29 899 2490 - www.austdac.com.au
An ISO 9001, ISO 14001, OHSAS 18001 Registered Company
The policy of GAI-Tronics is one of continuous improvement; therefore the company reserves the right to change specifications without notice.

B173-3-0113B/CN37470-001